

# Heat Exchangers

Installation

Operation

Maintenance



The information supplied in this manual is based on over four decades of field experience with our heat exchangers. Following the instructions contained in this manual will extend the service life of your heat exchanger.

Please note that all heat exchangers will eventually fail, even if they have been properly installed and well maintained. Our experience shows that some of the most common reasons for failure are: erosion, corrosion, freezing, water hammer, over-pressurization, and metal fatigue induced by vibration, thermal cycling, and pressure cycling.

When a heat exchanger fails, the likely result is contamination of the process and/or service fluids. If this would be a serious problem for your system, steps should be taken to protect your system to eliminate or reduce the impact of such contamination. Depending on the type of failure, one or both fluids could leak into the atmosphere.

Should assistance in installation or repair of any equipment be required, please contact Xchanger at:

Mail: 1401 South 7<sup>th</sup> Street  
Hopkins, MN 55343 USA  
Ph: 952-933-2559  
Fax: 952-933-5647  
E-mail: [info@xchanger.com](mailto:info@xchanger.com)  
Web: [xchanger.com](http://xchanger.com)

# TABLE OF CONTENTS

|       |  |           |
|-------|--|-----------|
| 1.0   | SCOPE OF THIS MANUAL.....                              | <u>5</u>  |
| 2.0   | RECEIVING THE HEAT EXCHANGER.....                      | <u>5</u>  |
| 2.1   | STORAGE.....   | <u>5</u>  |
| 3.0   | MOUNTING LOCATION.....                                 | <u>5</u>  |
| 3.1   | BG/C/D/HP/TV SERIES.....                               | <u>6</u>  |
| 3.2   | AA/LC/OC SERIES.....                                   | <u>6</u>  |
| 3.3   | HR SERIES.....   | <u>7</u>  |
| 4.0   | INSTALLATION.....                                      | <u>7</u>  |
| 4.1   | BG/C/D/HP/TV SERIES.....                               | <u>8</u>  |
| 4.1.1 | Drainable Tube Circuits.....                           | <u>8</u>  |
| 4.1.2 | Steam Piping.....                                      | <u>8</u>  |
| 4.1.3 | Steam Trap Selection.....                              | <u>9</u>  |
| 4.1.4 | Refrigerant Circuit.....                               | <u>10</u> |
| 4.1.5 | Housing Drain Trap.....                                | <u>10</u> |
| 4.2   | AA/LC/OC SERIES.....                                   | <u>10</u> |
| 5.0   | START-UP.....  | <u>11</u> |
| 5.1   | BG/C/D/HP/TV SERIES.....                               | <u>11</u> |
| 5.2   | AA/LC/OC SERIES.....                                   | <u>11</u> |
| 6.0   | MAINTENANCE.....                                       | <u>11</u> |
| 6.1   | LUBRICATION.....                                       | <u>11</u> |
| 6.1.1 | BG/C/D/HP/HR/TV SERIES.....                            | <u>11</u> |
| 6.1.2 | AA/LC/OC SERIES.....                                   | <u>11</u> |
| 6.2   | BG/C/D/HP/TV SERIES CORE REMOVAL AND INSTALLATION..... | <u>12</u> |
| 6.2.1 | BG/C/D/TV SERIES Core Removal.....                     | <u>12</u> |
| 6.2.2 | HP SERIES Core Removal.....                            | <u>12</u> |
| 6.2.3 | BG/C/D/HP/TV SERIES Core Installation.....             | <u>12</u> |
| 6.3   | CLEANING.....  | <u>13</u> |
| 6.3.1 | AA/HR/OC SERIES Internal Gas Passages.....             | <u>14</u> |
| 6.3.2 | AA/HR/LC/OC SERIES Service Gas Passages.....           | <u>14</u> |
| 6.3.3 | BG/C/D/HP/TV SERIES Gas Passages.....                  | <u>14</u> |
| 6.3.4 | BG/C/D/HP/LC/TV SERIES Fluid Passages.....             | <u>14</u> |
| 6.4   | FREEZING PROTECTION – BG/C/D/HP/LC/TV SERIES.....      | <u>14</u> |
| 6.4.1 | Drainable Circuits.....                                | <u>14</u> |
| 6.4.2 | Non-trapped Circuits.....                              | <u>14</u> |
| 6.4.3 | Trapped Circuits.....                                  | <u>15</u> |

|     |   |                    |
|-----|---|--------------------|
| 7.0 | SPARE PARTS.....                                | <a href="#">15</a> |
| 7.1 | BG/C/D/HP/TV SERIES.....                        | <a href="#">15</a> |
| 7.2 | AA/LC/OC SERIES.....                            | <a href="#">15</a> |
| 7.3 | HR SERIES.....                                  | <a href="#">15</a> |
| 8.0 | LIMITED WARRANTY.....                           | <a href="#">16</a> |
| 8.1 | LIMITED WARRANTY PERIOD.....                    | <a href="#">16</a> |
| 8.2 | TERMS.....                                      | <a href="#">16</a> |
| 8.3 | DISCLAIMER OF IMPLIED AND OTHER WARRANTIES..... | <a href="#">16</a> |
| 8.4 | LIMITATIONS ON LIABILITY .....                  | <a href="#">16</a> |

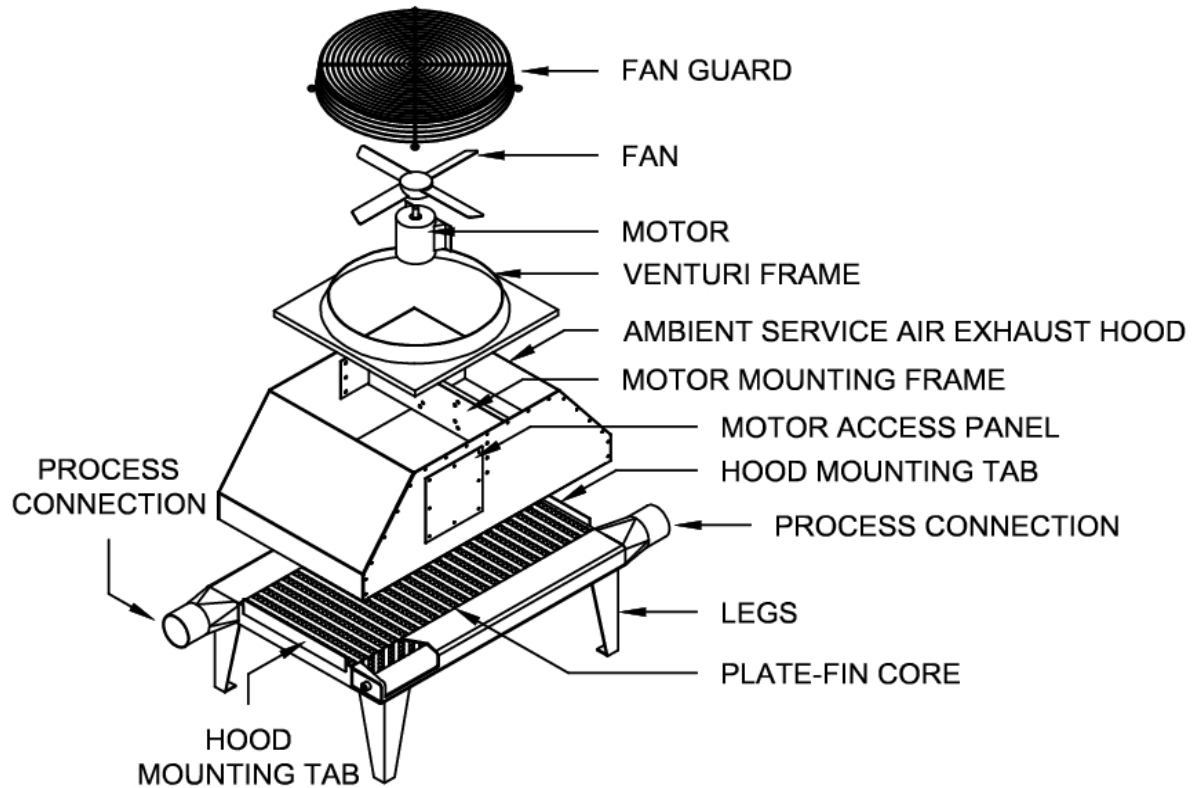

## AA Series Heat Exchangers

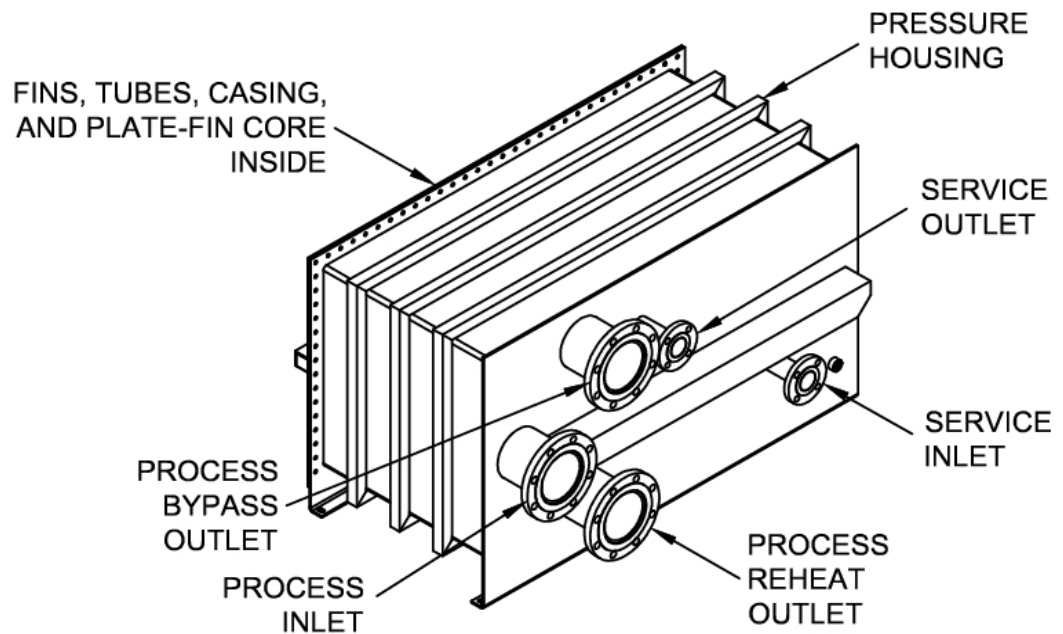

## BG Series Heat Exchangers

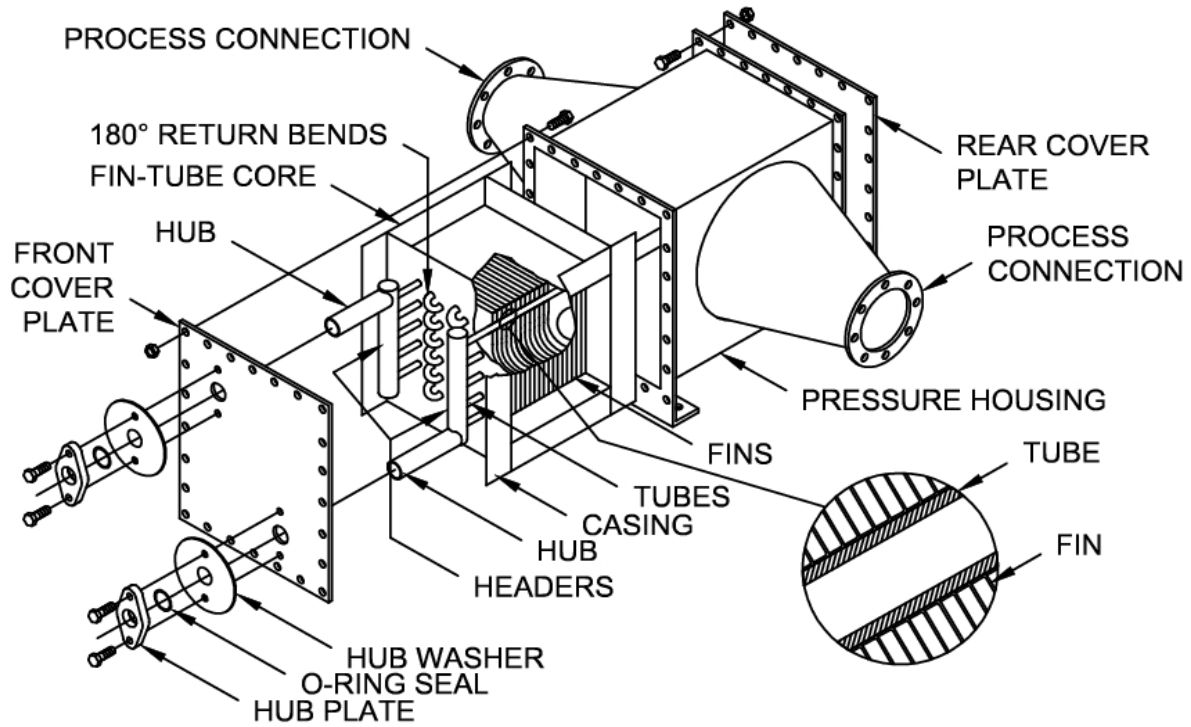

## C/TV Series Heat Exchangers

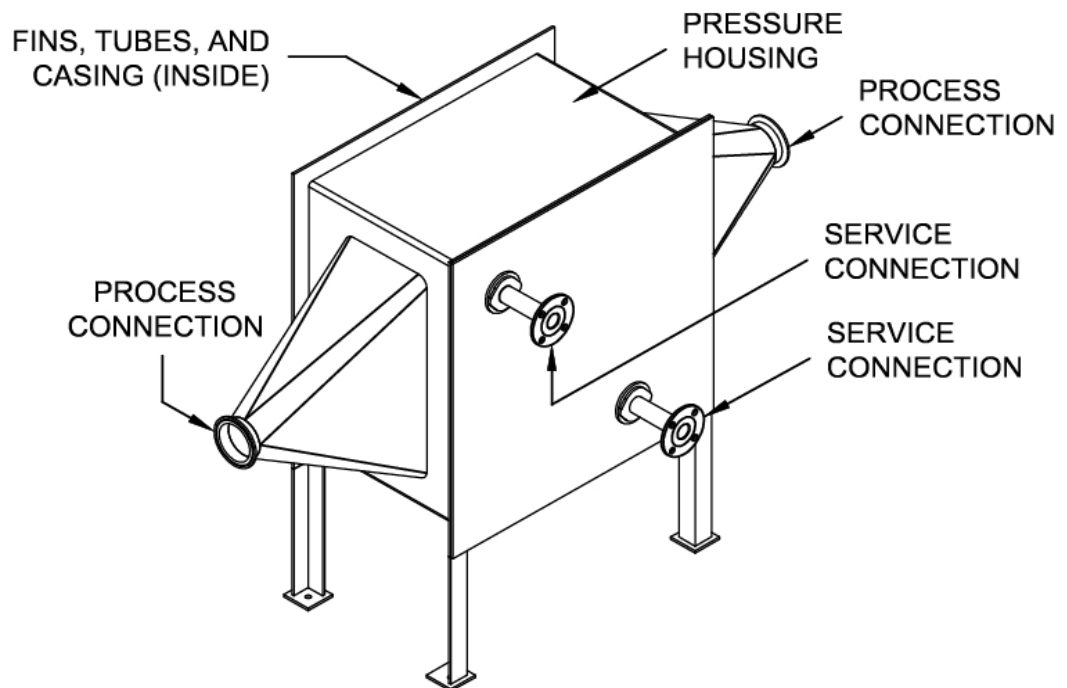

## D Series Heat Exchangers

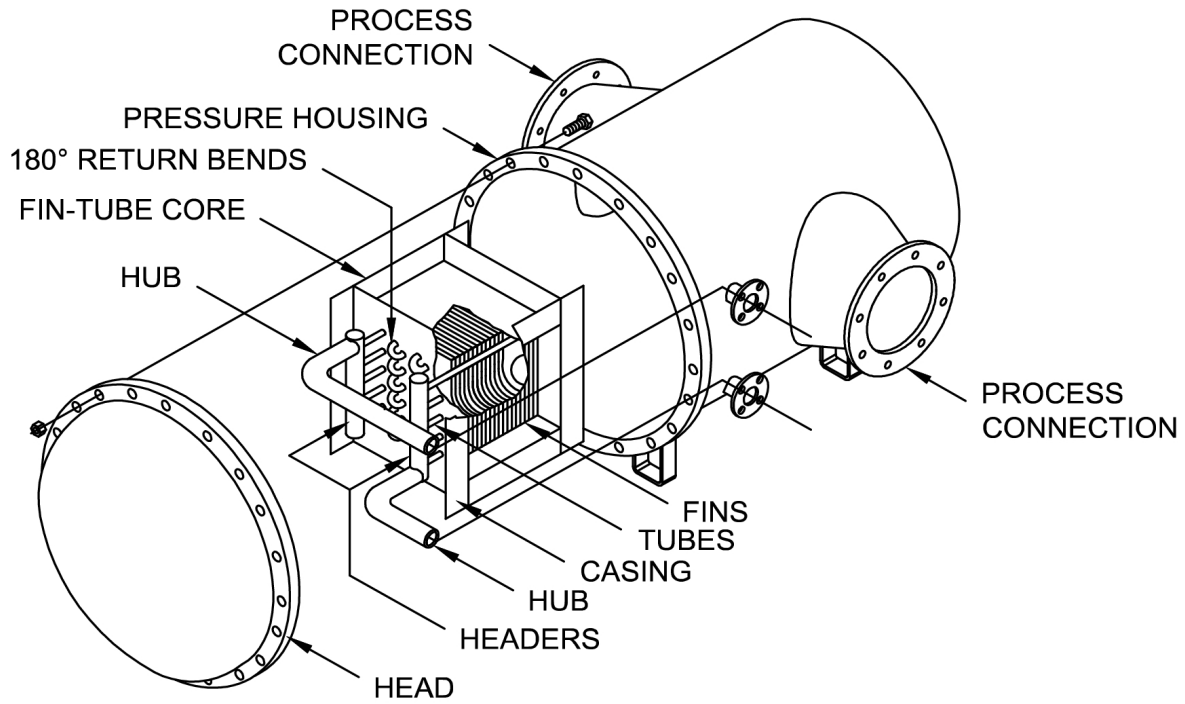

## HP Series Heat Exchangers

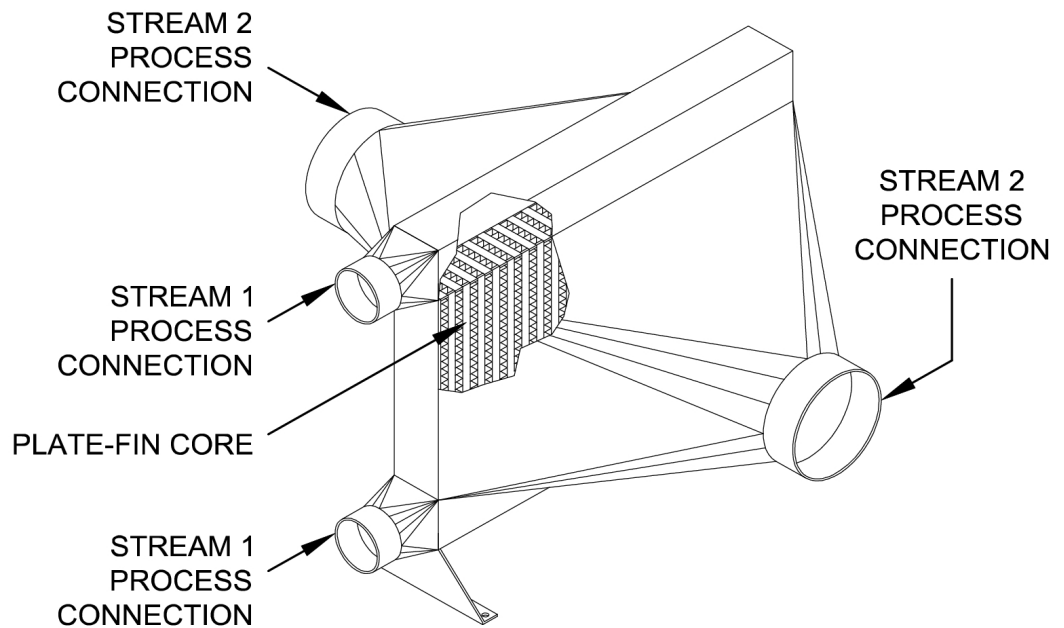

## HR Series Heat Exchangers



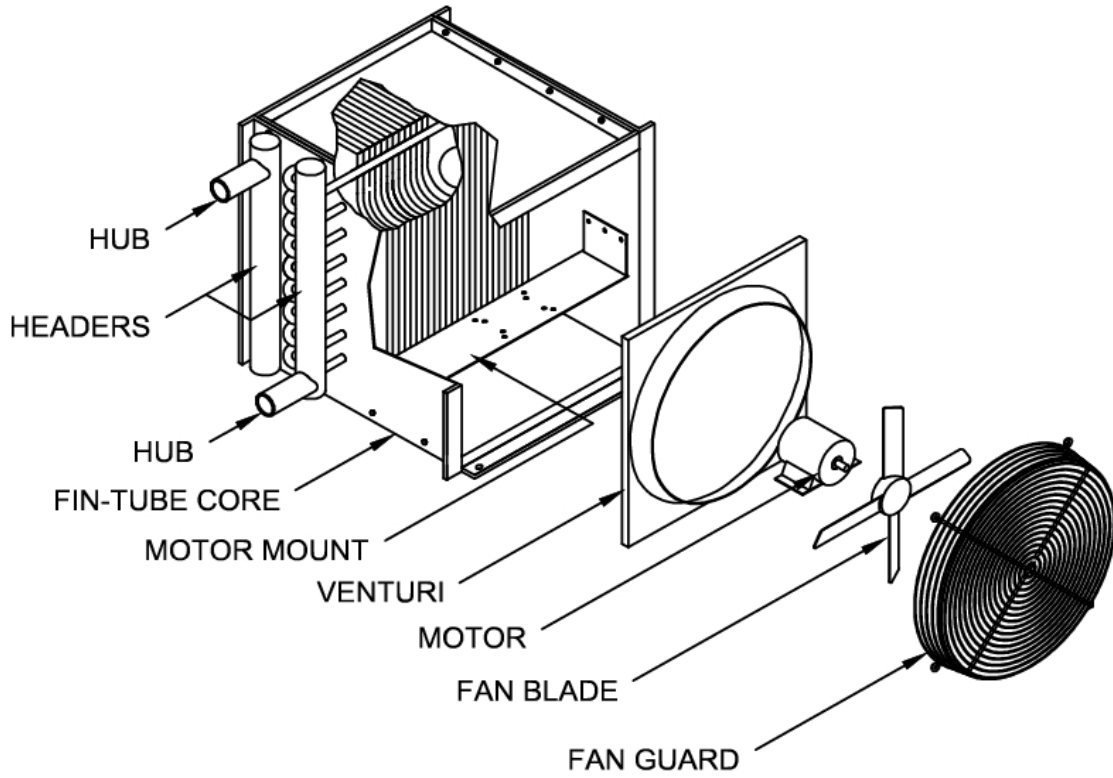

## LC Series Heat Exchangers

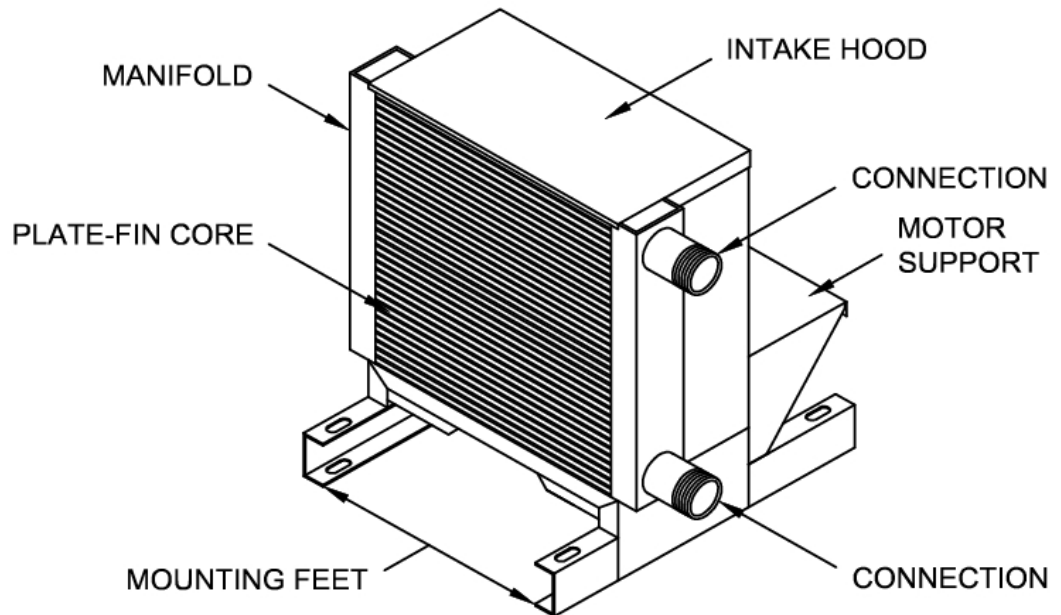

## OC Series Heat Exchangers

## 1.0 SCOPE OF THIS MANUAL

This manual describes the appropriate procedures for the use and care of Xchanger AA, BG, C, D, HP, HR, LC, OC, and TV Series heat exchangers. Warranty and service contact information is also included.

Due to the custom nature of all Xchanger heat exchangers, this manual discusses the characteristics and procedures that are common to all exchangers. It is imperative to carefully review all sections in this manual pertaining to the model and the service of your heat exchanger. Unit specific information not included in this manual will be shown on or included with the data sheet and certified drawing that characterize each distinct exchanger design. Information about motors and any accessories provided with an exchanger would also be separate from this manual.

## 2.0 RECEIVING THE HEAT EXCHANGER

The unit should be examined thoroughly upon receipt. The unit should have no cracks, dents, or deformations.

For AA-Series units with a manifold access port or ports, the unit is shipped with the port(s) sealed, covered, and ready for standard operation. The unit should be examined to ensure that all parts of the access port(s) are attached and undamaged and that all fasteners are tight.

Damage to either the unit or its crating should be immediately noted on the freight receipt. If the shipment was made F.O.B. our factory, damage claims should be filed with the responsible carrier.

Accessories, when ordered, are often shipped on the same skid as the heat exchanger. AA and LC Series accessories may be shipped inside the exhaust hood of the heat exchanger. Accessories for C, D, and TV Series units may be shipped inside the box protecting the service side connections. If too large to fit in these areas, a separate box containing the accessories may be attached to the skid. This box will be mentioned on the Bill of Lading. Check for any accessories before discarding the skid.

### 2.1 STORAGE

If the unit will not be placed into operation for an extended period of time, it should be left on the shipping skid. Store in a clean, dry, and protected area. All openings should be covered to protect interior surfaces. Unprotected carbon steel should be sprayed with a light coating of a rust inhibitor.

## 3.0 MOUNTING LOCATION

If the heat exchanger is located at the inlet or discharge of a blower with a pulsating flow, such as a Roots type rotary lobe blower, the heat exchanger must be protected from the pulsation by a chambered silencer.

The heat exchanger must be isolated from system vibrations using flexible piping connections and isolation pads on the mounting feet. Vibration can cause work-hardening and failure of the heat exchanger.

The process gas stream should be free of particulate. If there is a possibility of particulate passing through the heat exchanger, a filter should be installed upstream of the heat exchanger.

Ample space should be provided on all sides to allow servicing when required.

For AA-Series units with a manifold access port or ports, the unit should be mounted to allow access to the port(s), including enough clearance for any equipment needed to reach into the manifold for inspection or cleaning purposes. Depending on the unit, the manifolds can be up to 5 feet long.

### 3.1 BG/C/D/HP/TV SERIES

To facilitate servicing a unit with a removable core, provide enough clear space to remove the core through the bolted access panel.

For cooling applications where vapors may condense from the gas stream, a proper drain trap arrangement is necessary (see section 4.1.5 titled BG/C/D/HP/TV SERIES Housing Drain Trap for more information).

The service fluid must not be allowed to freeze or damage to the core will result (see section 6.4 titled FREEZING PROTECTION – BG/C/D/HP/TV SERIES for more information). With the exception of exchangers designed for evaporative heat transfer, heating of the service fluid beyond its boiling point may damage the core.

### 3.2 AA/LC/OC SERIES

The heat exchanger should be mounted in a well ventilated area, preferably outdoors, as these units dissipate heat to the ambient air. If the unit is installed indoors and ducting of the service air is required, a booster fan should be used to convey the air through the duct.

The service airflow may be directed vertically or horizontally. A minimum clearance of 2 feet around the heat exchanger base is essential for proper cooling air flow. When designing the system layout, it is important not to restrict the intake or exhaust air flow, or the exchanger may not perform as rated.

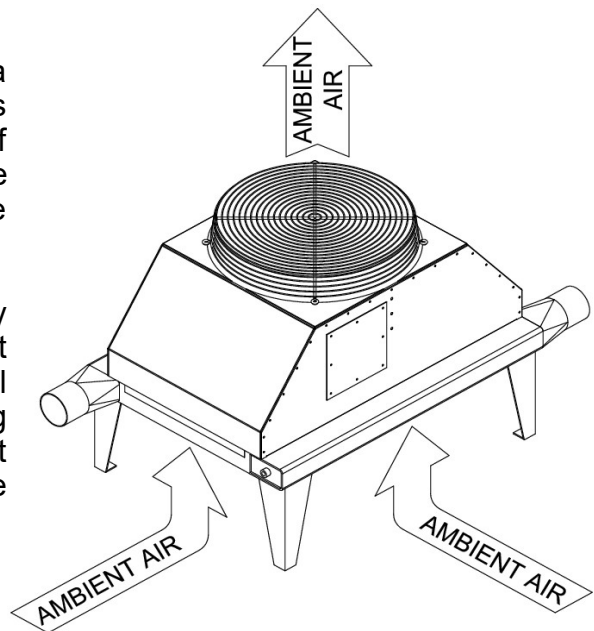

### 3.3 HR SERIES

If installed in a very warm or very cool location, the ambient conditions could interfere with the intended heat transfer. The effects of the ambient conditions can be mitigated by insulating the exchanger after installation.

## 4.0 INSTALLATION

The heat exchanger should be supported and secured by the mounting feet. The heat exchanger nozzles are not designed for external loading or moments. All piping should be supported independently of the heat exchanger, and any flex connectors present should not add loads or moments to the heat exchanger connections. Any debris in the piping should be removed before the heat exchanger is installed, as the core of the exchanger could trap any particles, causing reduced performance and/or damage to the core.

For AA-Series units with a manifold access port or ports, the ports are not designed to support additional equipment, piping, ducting, etc.

The unit is equipped with labels indicating gas flow direction and service fluid inlets and outlets. Connections must be installed as labeled. The certified drawing also indicates the flow direction and should be consulted during installation.

If pulsating gas flow is supplied to the unit, a chambered silencer must be installed between the blower and the exchanger. Flex connectors should be used to absorb vibration and thermal loading from the system piping. If vibrations may pass through the mounting skid, isolation pads should be used between the skid and the mounting feet of the heat exchanger. Pulsation and/or vibration can cause metal fatigue and lead to failure of the heat exchanger.

If the heat exchanger is used in a pneumatic conveying system, a check valve should be placed between the air lock and the heat exchanger. This will help to prevent clogging the heat exchanger with the product being conveyed.

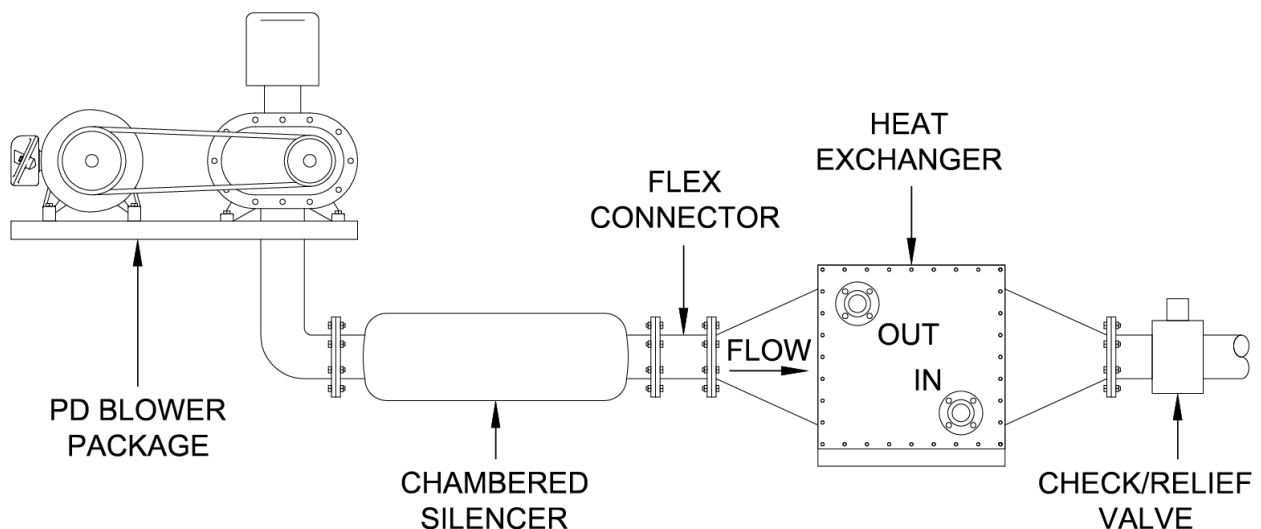

## 4.1 BG/C/D/HP/TV SERIES

The orientation for which the heat exchanger is designed is noted on the certified drawing. A unit that is designed for horizontal gas flow may not perform to specification if it is installed in a vertical flow orientation, and a unit that is designed for counter flow heat transfer may not perform to specification if piping is installed in a parallel flow orientation.

Attachment to the service connections should be made using industry standard practices. If special valves, controls, traps, etc., are provided by Xchanger, separate instructions may be attached. If shut off valves are installed on both of the service lines, a pressure relief valve should be installed on the heat exchanger side of one of the shut off valves to prevent over pressurizing the unit. If required, a pressure relief valve should be selected per industry standard practices.

On standard heat exchangers, there is a 3/4 or 1 inch female NPT drain coupling either on the bottom of the front cover or the bottom of the housing. Condensate that forms on the outside of the fins can be drained through this coupling to a drain leg or trap.

### 4.1.1 Drainable Tube Circuits

These units should be installed with a slight slope toward the service connection side of the exchanger.

### 4.1.2 Steam Piping

Proper installation, piping, and trapping is necessary to ensure satisfactory operation and prevent damage under normal operating conditions. These installation requirements must be followed to prevent common failures and performance problems:

- Provide swing joints or flexible fittings in all piping connections adjacent to the heat exchanger. This absorbs the thermal expansion and contraction of the piping.
- Condensate must flow freely from the heat exchanger at all times to prevent physical damage to the core caused by water hammer, unequal thermal stresses, freeze-up, or corrosion.
- Do not pitch the heat exchanger. The mounting position should be level.
- Control each heat exchanger core separately when installing multiple cores.
- Do not modulate systems with overhead or pressurized returns unless the condensate is drained by gravity to a receiver, vented to atmosphere, and returned to the condensate main by a condensate pump.
- Pitch all supply and return piping down a minimum of 1 inch per 10 feet in the direction of steam flow.
- Do not drain steam mains or take-offs through the heat exchanger. Drain steam

mains ahead of the heat exchanger through a steam trap into the condensate return line.

- Do not bush or reduce the steam condensate return piping smaller than the heat exchanger connection. Run return pipe full size to a steam trap (except for a short nipple screwed directly into the condensate connection of the steam trap).
- Overhead condensate return lines require 1 PSIG pressure at the steam trap inlet for each 2 feet of elevation to assure continuous condensate removal.
- When an overhead condensate return line is installed, provisions should be incorporated into the piping system to allow condensate to drain from the heat exchanger during down time.
- The end of the steam supply main must be trapped.
- A vacuum breaker must be installed downstream of the control valve or shut off valve.

#### 4.1.3 Steam Trap Selection

Proper steam trap selection and installation is necessary for satisfactory heat exchanger performance and service life:

- Select a steam trap based on the maximum possible condensate flow rate along with the recommended load factors.
- Locate the steam trap discharge at least 12 inches below the heat exchanger condensate return connection. This will provide sufficient hydrostatic head pressure to overcome trap losses and assure complete removal of the condensate from the heat exchanger.
- Float and thermostatic type steam traps are preferred because of their gravity drain and continuous discharge operation.
- Use a float and thermostatic type steam trap with gravity condensate return and automatic controls where there is a possibility of a low pressure steam supply.
- Use bucket traps only when steam supply is not modulated and is over 25 PSIG.
- When installed for series airflow, size steam traps for each heat exchanger core using the capacity of the first heat exchanger core (in airflow direction).
- Trap each heat exchanger separately. This will prevent condensate holdup in the heat exchanger cores.
- Install strainers as close as possible to the inlet side of a steam trap.

#### 4.1.4 Refrigerant Circuit

Direct expansion refrigerant circuits are shipped open and uncharged. They must be evacuated and charged. If you need assistance, contact a local refrigeration contractor.

#### 4.1.5 Housing Drain Trap

In applications where vapors are expected to condense from a horizontal gas flow, an automatic drain trap should be installed. Approximately 12 inches total clearance under the housing box is required, or 9 inches below the standard mounting feet.

For installations where the gas flow is vertical, any condensed vapors will fall out of the low side transition, due to gravity.

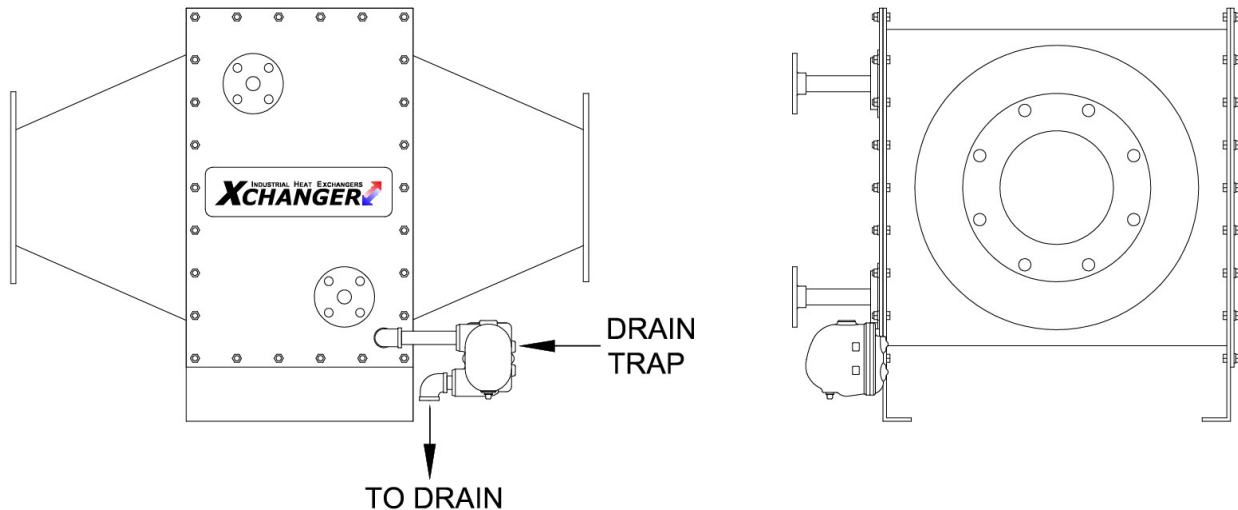

#### 4.2 AA/LC/OC SERIES

The electric motor must be wired on site. On many air cooled heat exchangers, the electrical service must be brought through the exhaust hood. Any holes in the exhaust hood should be sealed to prevent air that has not passed through the core from entering, thereby short-circuiting the core. Refer to the motor nameplate and motor manual for electrical requirements and installation instructions.

## 5.0 START-UP

After carefully observing all the points listed under Section 4.0 INSTALLATION, the unit is ready for start-up.

### 5.1 BG/C/D/HP/TV SERIES

The service fluid should be supplied to the equipment at 100% of the design flow rate before the process gas is directed to the equipment. For steam applications, the steam should be turned on full for at least ten minutes before the airflow is started to prevent water hammer, freezing, and excessive thermal stresses. After the process and service fluids have been supplied to the unit, check for leaks.

### 5.2 AA/LC/OC SERIES

Before starting the electric motor, the following checklist should be used:

- The impeller hub should be secure on the motor shaft.
- The impeller should rotate freely.
- Electrical wiring should be safely secured.
- The air flow path should be open (i.e. packing material removed).

After starting the motor, verify that the impeller is rotating in the proper direction. The data sheet and certified drawing should state the design flow direction for the ambient air.

For AA-Series units with a manifold access port or ports, confirm that the covers and gaskets are installed over the manifold access ports and that all fasteners are tight enough to prevent leakage around the gasket.

## 6.0 MAINTENANCE

Depending on the model and operating environment, the maintenance requirements may vary.

### 6.1 LUBRICATION

#### 6.1.1 BG/C/D/HP/HR/TV SERIES

No lubrication is required for the heat exchangers. Accessories may require lubrication per their manuals.

#### 6.1.2 AA/LC/OC SERIES

Refer to the maintenance instructions provided with the motor(s).



## 6.2 BG/C/D/HP/TV SERIES CORE REMOVAL AND INSTALLATION

It may be necessary to occasionally remove the fin-tube core from the housing for inspection and cleaning.

For units with removable cores, the following steps describe the procedure for removing the fin-tube core from the heat exchanger housing. Units that are fully-welded will need to be returned to the factory for service. [Reference pages 1 - 4 for component terminology.]

### 6.2.1 BG/C/D/TV SERIES Core Removal

1. Disconnect the service fluid and remove any connections from the service hubs (i.e. sweat on copper flanges, screwed on threaded flanges, etc.). Some units have welded service connections that may need to be cut off to remove the core. If the core and cover are welded together, the flanges do not need to be removed, as the cover will remain with the core.
2. Remove the bolts securing the hub plate assemblies to the front cover.
3. Remove the hub plate assembly (hub plate, O-ring, and backing washer). Some prying with a screwdriver or similar tool may be required to break the bond of the sealant.
4. Remove the bolts securing the front and rear housing covers to the housing. Some units with removable cores may only have one removable cover.
5. Remove the bolted covers. Some prying with a screwdriver or similar tool may be required to break the bond of the sealant. Exercise caution to avoid dropping the removable covers.
6. Remove the bolts securing the core to the housing. Check both sides.
7. Remove the core from the housing by pulling evenly on accessible headers, 180° tube return bends, or the casing. Take care not to damage the headers or return bends.

### 6.2.2 HP SERIES Core Removal

1. Remove the flange bolts around the removable dished head cover.
2. Disconnect the core connections from the internal service connections.
3. Remove the bolts holding the core to the side of the housing.
4. Remove the core from the housing by pulling evenly on the headers.

### 6.2.3 BG/C/D/HP/TV SERIES Core Installation

Install the core in the reverse order of removal, noting the following:

1. Slide the core into the housing and attach the casing to the side of the housing with weld nuts, bolt holes, and/or positioning tabs.

For replacement cores, the holes in the casing which hold the core against the side of the housing may not match the holes on the original core. If not, new holes will need to be drilled as follows:

- a. Slide the core into the housing such that the core face is centered in the

- transition opening.
- b. Mark the locations of the housing holes on the casing.
  - c. Remove the core and drill the holes where marked. When drilling the holes, place a wooden block between the casing and the return bends to prevent damage to the core's tubing.
  - d. Reinstall the core into the housing.
2. For HP Series exchangers, the internal service connections must be reattached prior to reinstalling the dished head cover.
  3. Clean the sealing surfaces on the covers and housing flanges with solvent to remove any oils or residue.
  4. Apply new gasket material to the housing flange as needed. Refer to the design data sheet supplied with the certified drawing for proper gasket material selection.
  5. Install covers, cover fastener assemblies, and, for BG/C/D/TV Series exchangers, the hub cover assemblies. To facilitate installing the hub cover assemblies, do not tighten the cover bolts until after the hub cover assemblies are installed. All bolts should be finger tight at this point. Units with covers welded to the internal core hubs will not have hub cover assemblies.

For C/TV Series replacement cores, the hub locations may not be identical to those of the original core. To check for proper alignment, install the front cover with the four corner bolts. Slide on the hub cover assemblies to check for alignment over the hubs of the replacement core. If the hub and cover bolt holes or welded studs do not match, new holes must be drilled and tapped into the cover and any studs must be removed and ground flush. The hub covers may be rotated such that the old bolt holes will not interfere with the new holes. Fill in the old holes to prevent gas leakage.

6. Tighten cover bolts.
7. Tighten the hub cover assembly bolts.
8. Refer to Section 5.0 for recommended start-up procedures.

### 6.3 CLEANING

Xchanger heat exchangers perform best when clean. It is recommended that they be prevented from becoming fouled since their design is such that once plugged or coated, it may not be possible to fully clean them. The sections below offer suggestions, where applicable, if cleaning is attempted.

### 6.3.1 AA/HR/OC SERIES Internal Gas Passages

The internal process gas passages in these heat exchangers are not cleanable unless the units are provided with bolted access panels. Filtered air is absolutely required for these units. If plugging does occur, core replacement is recommended.

For AA-Series units with a manifold access port or ports, when the access panel is removed, the gaskets and mounting surfaces should be cleaned, to ensure a good seal, before reinstalling the gasket and cover. Fasteners should be tightened enough to prevent leakage. The gasket may bulge slightly due to bolt tightening – this is not a problem.

### 6.3.2 AA/HR/LC/OC SERIES Service Gas Passages

For dirt/dust contamination, a soap and water wash is usually adequate to clean the service side of these units. If not, the use of an appropriate solvent or compressed air is recommended. Exercise caution when selecting a solvent to avoid corroding contact materials. Pressure washers will damage the fins and should not be used.

### 6.3.3 BG/C/D/HP/TV SERIES Gas Passages

These heat exchangers may require disassembly for cleaning. See Section 6.2 for disassembly instructions. Once access is obtained, the cleaning options described in Section 6.3.2 can be used.

### 6.3.4 BG/C/D/HP/LC/TV SERIES Fluid Passages

An appropriate solvent or cleaner compatible with the tube material can be circulated through the internal core tubes to attempt to restore a fouled heat exchanger to its original capacity.

## 6.4 FREEZING PROTECTION – BG/C/D/HP/LC/TV SERIES

### 6.4.1 Drainable Circuits

If the heat exchanger is equipped with a drainable tube circuit, the tubes can be drained by simply opening the service inlet and outlet to atmosphere. These units should be installed with a slight slope toward the service connection end to facilitate complete drainage.

### 6.4.2 Non-trapped Circuits

These tube circuits run horizontally and downward across the exchanger. If the exchanger is installed level, when the service inlet and outlet are opened to atmosphere, the service fluid may drain out of the low connection sufficiently to prevent freezing damage. If the exchanger is installed out of level, some service fluid will hang up in the now trapped points of the core. In this case, antifreeze should be added as discussed on the following page.

### 6.4.3 Trapped Circuits

These circuits run downward and upward, like the trap under a sink, and therefore are not drainable. Antifreeze should be added as discussed below.

Antifreeze should be added to the core to provide freezing protection, per the following procedure.

1. Open the water inlet and outlet to atmosphere and allow the core to drain as completely as possible.
2. Add antifreeze to the core and circulate the solution through the core for approximately fifteen minutes.
3. Check the concentration for adequate freeze protection for your area. If the concentration is not sufficient, repeat steps 1 & 2 as necessary.

## 7.0 SPARE PARTS

### 7.1 BG/C/D/HP/TV SERIES

Typically, no spare parts are recommended. Any special parts or accessories would be noted on the data sheet, certified drawing, or on accompanying documentation.

Please note that the manufacturing and shipping time for replacement cores is often 6 weeks. If this length of downtime would present a significant problem, it is advisable to stock a spare core.

### 7.2 AA/LC/OC SERIES

A spare electric motor is recommended. Similar to the BG/C/D/HP/TV Series above, any special parts would be noted on a case by case basis.

For AA-Series units with a manifold access port or ports, the gasket may be single use, such as RTV silicone or expanded PTFE, or multi use, such as cut silicone or Buna-N. For either type, a replacement gasket is available with a typical 1-2 week lead time.

### 7.3 HR SERIES

Typically, no spare parts are recommended. Similar to the BG/C/D/HP/TV Series above, any special parts would be noted on a case by case basis.

## 8.0 LIMITED WARRANTY

### 8.1 LIMITED WARRANTY PERIOD

The sooner of either:

- 12 months from date of start-up
- 18 months from date of shipment from Xchanger

### 8.2 TERMS

Xchanger warrants only to the original non-consumer Customer during the Limited Warranty Period that the Product will be free from defects in material and workmanship under intended use and service.

Provided our examination shows the item to be defective, Xchanger, at its exclusive option, will repair the defective Product at our facility, provide a replacement Product, or refund 100% of Xchanger's original selling price. In order to make use of Xchanger's Limited Warranty, the Customer must have delivered the Product to our facility at the Customer's expense. Under no circumstances should the allegedly defective Product be returned unless the Customer has written permission from Xchanger to do so.

The part or parts must have been used as intended and in accordance with our instructions. No allowance will be made for repairs or alterations made without the written consent of an Xchanger representative.

### 8.3 DISCLAIMER OF IMPLIED AND OTHER WARRANTIES

THE PRECEDING EXPRESS LIMITED WARRANTY IS THE EXCLUSIVE WARRANTY PROVIDED BY XCHANGER, WITH RESPECT TO THE PRODUCT, IN LIEU OF ALL OTHER REPRESENTATIONS AND WARRANTIES, EXPRESS OR IMPLIED. XCHANGER PROVIDES NO REPRESENTATION OR WARRANTY OF MERCHANTABILITY OR FITNESS OF THE PRODUCT FOR A PARTICULAR PURPOSE.

While Xchanger may assist the Customer with Product selection or provide opinions with regard to a proposed application, Xchanger does not assume any responsibility for suitability of the Customer's Product with respect to the proposed application, operating environment, or the Customer's methods or system design. The Customer is solely responsible for making the determination that an Xchanger Product is suitable for the Customer's application and any associated requirements.

### 8.4 LIMITATIONS ON LIABILITY

The Limited Warranty is provided only to the original non-consumer purchaser of the Product and not to any subsequent owners or users. The Limited Warranty does not cover performance degradation or damages resulting from plugging, fouling, improper installation, improper handling, failure to adhere to applicable instructions, erosion, corrosion, freezing, water hammer, system induced metal fatigue, misuse, neglect, alteration, accident, operating at temperatures or pressures in excess of those for which

the equipment was specified and furnished or any other reason not related to defects in material or workmanship of the Product.

The liability of Xchanger is limited to our option of the repair, replacement, or refund of any Product which has been found defective by our examination after it has been returned F.O.B. our factory. Such repair, replacement, or refund shall constitute the extent of our obligation.

In the event that Xchanger manufactures a Product based on information provided by the Customer or on the Customer's behalf and such information is inaccurate or excludes relevant facts necessary to offering a Product selection including, but not limited to, those pertaining to operating, design, and environmental conditions, then Xchanger will not have any responsibility to the Customer under this Limited Warranty or otherwise.

XCHANGER'S LIABILITY ON ANY CLAIM OF ANY KIND RESULTING FROM ANY CAUSE WHATSOEVER, INCLUDING WITHOUT LIMITATION, NEGLIGENCE, FOR ANY LOSSES OR DAMAGES ASSOCIATED WITH AN ORDER OR WITH THE PERFORMANCE, OPERATION, OR USE OF A PRODUCT ASSOCIATED WITH AN ORDER SHALL UNDER NO CIRCUMSTANCES EXCEED THE PRICE ALLOCABLE TO THE EQUIPMENT OR UNIT THEREOF WHICH GIVES RISE TO THE CLAIM AND SHALL TERMINATE THE SOONER OF EITHER 1 YEAR AFTER THE COMPLETION OF INSTALLATION OF THE EQUIPMENT OR 18 MONTHS AFTER THE SHIPMENT OF THE EQUIPMENT FROM XCHANGER'S FACILITY. XCHANGER WILL NOT BE LIABLE FOR ANY SPECIAL, INCIDENTAL, OR CONSEQUENTIAL DAMAGES INCLUDING, BUT NOT LIMITED TO, LOSS OF PROFITS OR REVENUE, LOSS OF USE OF THE EQUIPMENT OR ANY ASSOCIATED EQUIPMENT, COST OF CAPITAL, COST OF SUBSTITUTE EQUIPMENT, FACILITIES OR SERVICES, DOWNTIME COSTS, OR CLAIMS OF SUBSEQUENT OWNERS FOR SUCH DAMAGES.

Motors, controls, accessories, instruments, and other purchased parts are warranted by their original manufacturers. Such warranties will be carried out in accordance with the usual terms thereof.





1401 7<sup>th</sup> STREET S.  
HOPKINS, MN 55343  
952-933-2559

[XCHANGER.COM](http://XCHANGER.COM)

X012021IOM